

Entanglement witnesses

Géza Tóth

¹Theoretical Physics, University of the Basque Country UPV/EHU, Bilbao, Spain

²IKERBASQUE, Basque Foundation for Science, Bilbao, Spain

³Wigner Research Centre for Physics

Entanglement Day, Wigner RCP, Budapest,
12:30 - 13:30, 4 September 2014.

1 Introduction

2 Entanglement witnesses

- Basic definitions
- Geometry of quantum states
- Linear entanglement witnesses
- Various constructions for entanglement witnesses
- Experiment with photons

3 Spin squeezing and entanglement

- Non-linear entanglement criteria
- Spin squeezing
- Generalized spin squeezing
- Experiments

Entanglement

Definition

A quantum state is called **separable** if it can be written as a convex sum of product states as [Werner, 1989]

$$\varrho = \sum_k p_k \varrho_1^{(k)} \otimes \varrho_2^{(k)},$$

where p_k form a probability distribution ($p_k > 0$, $\sum_k p_k = 1$), and $\varrho_n^{(k)}$ are single-qudit density matrices. A state that is not separable is called **entangled**.

Multipartite entanglement

Definition

A state is **(fully) separable** if it can be written as

$$\sum_k p_k \varrho_1^{(k)} \otimes \varrho_2^{(k)} \otimes \dots \otimes \varrho_N^{(k)}.$$

Definition

A pure multi-qubit quantum state is called **biseparable** if it can be written as the tensor product of two multi-qubit states

$$|\Psi\rangle = |\Psi_1\rangle \otimes |\Psi_2\rangle.$$

Here $|\Psi\rangle$ is an N -qubit state. A mixed state is called biseparable, if it can be obtained by mixing pure biseparable states.

Definition

If a state is not biseparable then it is called **genuine multi-partite entangled**.

k -particle entanglement

- Similarly, one can define N -qubit states with k -particle entanglement.
- N -particle entanglement \equiv genuine multipartite entanglement.

Examples

Examples

Two entangled states of four qubits:

$$|GHZ_4\rangle = \frac{1}{\sqrt{2}}(|0000\rangle + |1111\rangle),$$

$$|\Psi_B\rangle = \frac{1}{\sqrt{2}}(|0000\rangle + |0011\rangle) = \frac{1}{\sqrt{2}}|00\rangle \otimes (|00\rangle + |11\rangle).$$

- The first state is genuine multipartite entangled, the second state is biseparable.

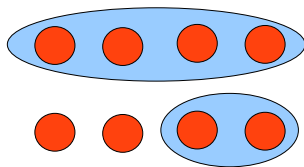

1 Introduction

2 Entanglement witnesses

- Basic definitions
- **Geometry of quantum states**
- Linear entanglement witnesses
- Various constructions for entanglement witnesses
- Experiment with photons

3 Spin squeezing and entanglement

- Non-linear entanglement criteria
- Spin squeezing
- Generalized spin squeezing
- Experiments

Theory of quantum entanglement

- Separable states form a convex set.

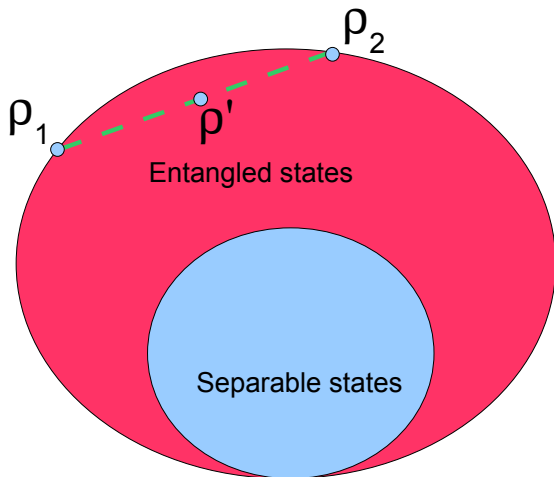

Theory of quantum entanglement II

- A more accurate picture:

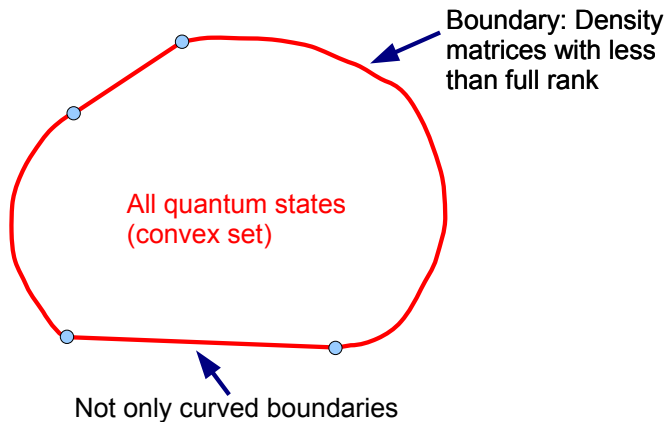

Theory of quantum entanglement III

- Together with the set of separable states:

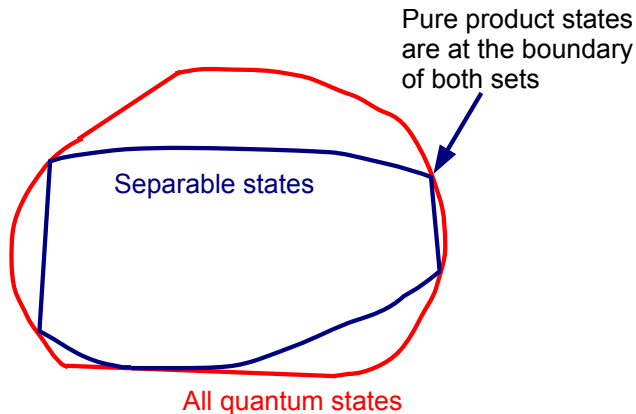

1 Introduction

2 Entanglement witnesses

- Basic definitions
- Geometry of quantum states
- **Linear entanglement witnesses**
- Various constructions for entanglement witnesses
- Experiment with photons

3 Spin squeezing and entanglement

- Non-linear entanglement criteria
- Spin squeezing
- Generalized spin squeezing
- Experiments

Entanglement witnesses

Definition

An **entanglement witness** \mathcal{W} is an operator that is positive on all separable (biseparable) states.

Thus, $\text{Tr}(\mathcal{W}\rho) < 0$ signals entanglement (genuine multipartite entanglement).

[Horodecki 1996; Terhal 2000; Lewenstein, Kraus, , Cirac, Horodecki 2002]

There are two main goals when searching for entanglement witnesses:

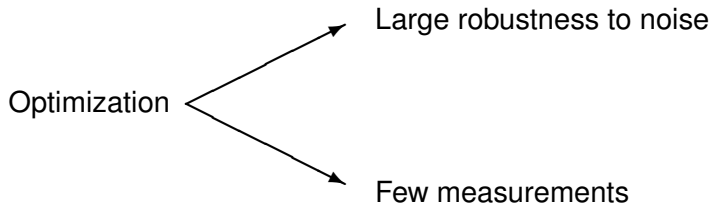

Convex sets for the entanglement witnesses

- Entanglement witnesses in the convex set picture

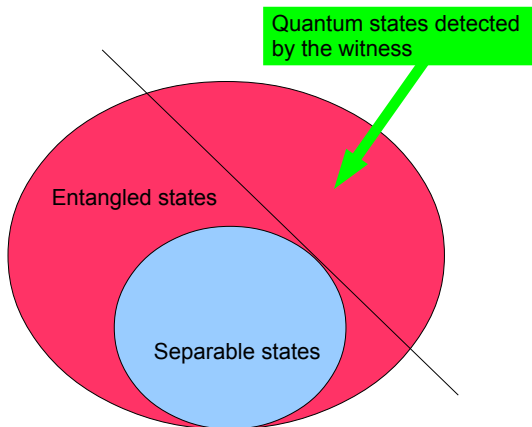

Convex sets for the entanglement witnesses II

- Entanglement witnesses can detect all entangled states since the set of separable states is convex.
- It is much more complicated to prove that a state is separable, since the set of entangled states is not convex.

Convex sets for the multipartite case

- The idea of convex sets also works for the multi-qubit case: A state is biseparable if it can be obtained by mixing pure biseparable states.

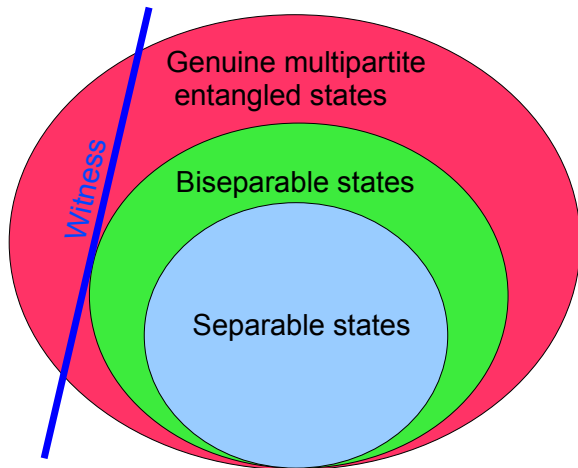

1 Introduction

2 Entanglement witnesses

- Basic definitions
- Geometry of quantum states
- Linear entanglement witnesses
- **Various constructions for entanglement witnesses**
- Experiment with photons

3 Spin squeezing and entanglement

- Non-linear entanglement criteria
- Spin squeezing
- Generalized spin squeezing
- Experiments

General scheme

- Witnesses are linear. Thus, the minimum of $\langle \mathcal{W} \rangle$ for separable states is the same as the minimum of $\langle \mathcal{W} \rangle$ for product states.
- A general scheme to get a witness is

$$\mathcal{W} = \mathcal{O} - \min_{\psi \text{ is of the form } \psi_1 \otimes \psi_2} \langle \mathcal{O} \rangle_{\psi}.$$

Witnesses based on correlations

Example

Witness with Heisenberg interaction

$$\mathcal{W}_{xyz} = \mathbb{1} \otimes \mathbb{1} + \sigma_x^{(1)} \otimes \sigma_x^{(2)} + \sigma_y^{(1)} \otimes \sigma_y^{(2)} + \sigma_z^{(1)} \otimes \sigma_z^{(2)}.$$

Proof. For product states of the form $|\Psi\rangle = |\Psi_1\rangle \otimes |\Psi_2\rangle$, we have

$$\langle \sigma_x \otimes \sigma_x \rangle + \langle \sigma_y \otimes \sigma_y \rangle + \langle \sigma_z \otimes \sigma_z \rangle = \sum_{l=x,y,z} \langle \sigma_l \rangle_{\Psi_1} \langle \sigma_l \rangle_{\Psi_2} \geq -1.$$

Here, we used the Cauchy-Schwarz inequality. Due to convexity, the inequality is also true for separable states.

The minimum for quantum states is -3 . Such a minimum is obtained for the state

$$\frac{1}{\sqrt{2}} (|01\rangle - |10\rangle).$$

Witnesses based on correlations II

- This can be used in spin chains. If the energy is lower than the minimal energy of the classical model then the ground state is entangled.

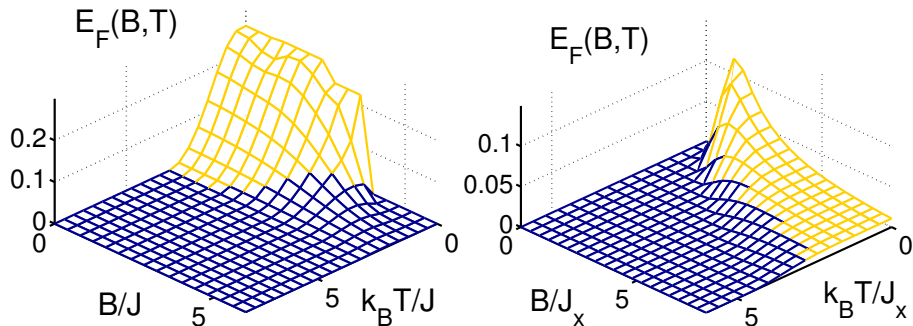

Heisenberg chain in an external field / Ising spin chain in a transverse field.

[G. Tóth, Phys. Rev. A 71, 010301(R) (2005); Ć. Brukner and V. Vedral, e-print quant-ph/0406040; M. R. Dowling, A. C. Doherty, and S. D. Bartlett, Phys. Rev. A 70, 062113 2004.]

Witnesses for multipartite entanglement

- Can be used to obtain qualitative information on the thermal ground state.

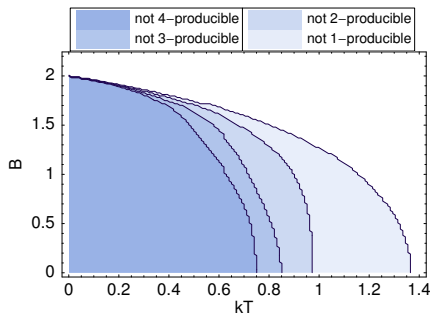

- XX-model in external field at finite temperature.
- not k -producible \equiv at least $(k + 1)$ -particle entanglement

[O. Gühne, G. Tóth, *New J. Phys.* 7, 229 (2005); O. Gühne, G. Tóth, *Phys. Rev. A* 73, 052319 (2006).]

PPT criterion-based witness I

- Let us take a bipartite separable state

$$\rho_{\text{sep}} = \sum_k p_k \rho_1^{(k)} \otimes \rho_2^{(k)}.$$

- After partial transposition on the second system, we get

$$\rho_{\text{sep}}^{T_2} = \sum_k p_k \rho_1^{(k)} \otimes (\rho_2^{(k)})^T \geq 0.$$

- $\rho_{\text{sep}}^{T_2}$ has a positive partial transpose (PPT).
- However, in general, there are states for which

$$\rho^{T_2} \not\geq 0.$$

They must be entangled.

PPT criterion-based witness II

Witness for state $|\Psi\rangle$

We construct an entanglement witness that detects the state $|\Psi\rangle$ as entangled:

$$W = |v\rangle\langle v|^{T1},$$

where $|v\rangle$ is the eigenvector of $|\Psi\rangle\langle\Psi|^{T1}$ with the smallest eigenvalue (which is negative).

Proof. For $|v\rangle$ we have $|\Psi\rangle\langle\Psi|^{T1}|v\rangle = \lambda|v\rangle$, where $\lambda < 0$. Then, we have

$$\text{Tr}(W|\Psi\rangle\langle\Psi|) = \text{Tr}(|v\rangle\langle v||\Psi\rangle\langle\Psi|^{T1}) = \lambda < 0$$

using $\text{Tr}(A^{T1}B) = \text{Tr}(AB^{T1})$. Thus, the witness detects the state $|\Psi\rangle$ as entangled. For every separable state

$$\text{Tr}(W\rho_{\text{sep}}) = \text{Tr}(|v\rangle\langle v|\rho_{\text{sep}}^{T1}) > 0,$$

using $\rho_{\text{sep}}^{T1} \geq 0$ (previous slide).

Projector witness for bipartite systems

Projector witness for state $|\Psi\rangle$

A witness detecting entanglement in the vicinity of a pure state $|\Psi\rangle$ is

$$\mathcal{W}_{\Psi}^{(P)} := \lambda_{\Psi}^2 \mathbb{1} - |\Psi\rangle\langle\Psi|,$$

where λ_{Ψ} is the maximum of the Schmidt coefficients for $|\Psi\rangle$.

[M. Bourennane, M. Eibl, C. Kurtsiefer, S. Gaertner, H. Weinfurter, O. Gühne, P. Hyllus, D. Bruß, M. Lewenstein, and A. Sanpera, Phys. Rev. Lett. 2004.]

Proof. Schmidt decomposition

$$|\Psi\rangle = \sum_k \lambda_k |k\rangle|k\rangle.$$

The maximum overlap with product states is $\max_k \lambda_k$. Hence,

$$\mathrm{Tr}(|\Psi\rangle\langle\Psi|_{\mathcal{Q}_1 \otimes \mathcal{Q}_2}) \leq \max_k \lambda_k^2.$$

Due to linearity,

$$\mathrm{Tr}(|\Psi\rangle\langle\Psi|_{\mathcal{Q}_{\mathrm{sep}}}) \leq \max_k \lambda_k^2.$$

Projector witness for multipartite systems

- A witness detecting genuine multi-qubit entanglement in the vicinity of a pure state $|\Psi\rangle$ is

$$\mathcal{W}_{\Psi}^{(P)} := \lambda_{\Psi}^2 \mathbb{1} - |\Psi\rangle\langle\Psi|,$$

where λ_{Ψ} is the maximum of the Schmidt coefficients for $|\Psi\rangle$, when all bipartitions are considered.

[M. Bourennane, M. Eibl, C. Kurtsiefer, S. Gaertner, H. Weinfurter, O. Gühne, P. Hyllus, D. Bruß, M. Lewenstein, and A. Sanpera, Phys. Rev. Lett. 2004]

Projector witness: examples

- GHZ states (robustness to noise is $\frac{1}{2}$ for large N !)

$$\mathcal{W}_{\text{GHZ}}^{(P)} := \frac{1}{2} \mathbb{1} - |\text{GHZ}_N\rangle\langle\text{GHZ}_N|.$$

- Cluster states (obtained in Ising chain dynamics)

$$\mathcal{W}_{\text{CL}}^{(P)} := \frac{1}{2} \mathbb{1} - |\text{CL}_N\rangle\langle\text{CL}_N|.$$

- Symmetric Dicke state with $\langle J_z \rangle = 0$

$$\mathcal{W}_{\text{D}(N,N/2)}^{(P)} := \frac{1}{2} \frac{N}{N-1} \mathbb{1} - |D_N^{(N/2)}\rangle\langle D_N^{(N/2)}|.$$

- W-state (e.g., $|1000\rangle + |0100\rangle + |0010\rangle + |0001\rangle$)

$$\mathcal{W}_{\text{W}}^{(P)} := \frac{N-1}{N} \mathbb{1} - |D_N^{(1)}\rangle\langle D_N^{(1)}|.$$

1 Introduction

2 Entanglement witnesses

- Basic definitions
- Geometry of quantum states
- Linear entanglement witnesses
- Various constructions for entanglement witnesses
- Experiment with photons

3 Spin squeezing and entanglement

- Non-linear entanglement criteria
- Spin squeezing
- Generalized spin squeezing
- Experiments

Experiment with photons

- A photon can have a horizontal (H) and a vertical (V) polarization.
- H/V can take the role of 0 and 1.
- Problem: photons do not interact with each other.

Photons II

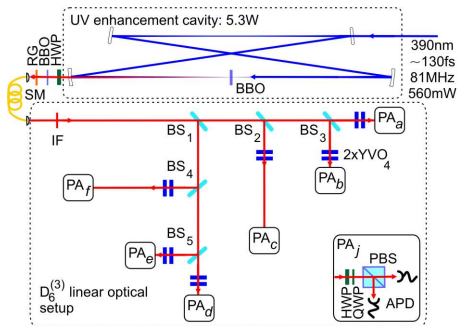

MPQ, Munich. Experiments with 6 photons.

[W. Wieczorek, R. Krischek, N. Kiesel, P. Michelberger, G. Tóth, and H. Weinfurter, Phys. Rev. Lett. 2009.]

$$|D_6^{(3)}\rangle = \frac{1}{\sqrt{20}} (|111000\rangle + |110100\rangle + \dots + |000111\rangle).$$

Photons III

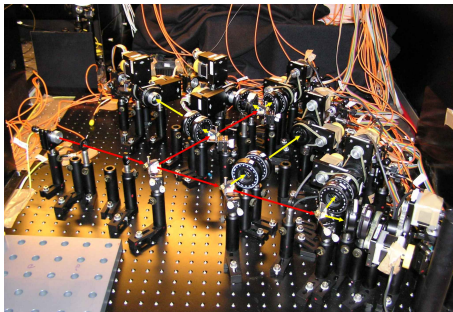

Photons IV

6-qubit Quantum state tomography

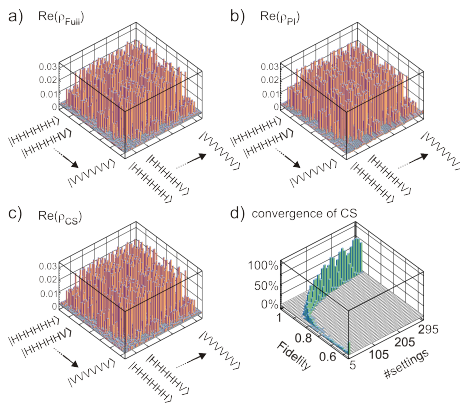

[C. Schwemmer, G. Tóth, A. Niggebaum, T. Moroder, D. Gross, O. Gühne, and H. Weinfurter, Phys. Rev. Lett 113, 040503 (2014).]

- Entanglement witnesses can be used for entanglement detection.

1 Introduction

2 Entanglement witnesses

- Basic definitions
- Geometry of quantum states
- Linear entanglement witnesses
- Various constructions for entanglement witnesses
- Experiment with photons

3 Spin squeezing and entanglement

- Non-linear entanglement criteria
- Spin squeezing
- Generalized spin squeezing
- Experiments

Variance-based criteria

For a bipartite system, for both parties

$$(\Delta A_k)^2 + (\Delta B_k)^2 \geq L_k.$$

For product states of the form $|\Psi\rangle = |\Psi_1\rangle \otimes |\Psi_2\rangle$, we have

$$(\Delta(A_1 + A_2))^2 = \langle(A_1 + A_2)^2\rangle - \langle A_1 + A_2\rangle^2 = (\Delta A_1)_{\Psi_1}^2 + (\Delta A_2)_{\Psi_2}^2$$

since for product states

$$\langle A_1 A_2 \rangle - \langle A_1 \rangle \langle A_2 \rangle = 0.$$

Hence,

$$(\Delta(A_1 + A_2))^2 + (\Delta(B_1 + B_2))^2 \geq L_1 + L_2.$$

This is also true for separable states due to the convexity of separable states.

[See Gühne, Phys. Rev. Lett. (2004) for an exhaustive study.]

Variance-based criteria II

Example: we have

$$(\Delta x)^2(\Delta p)^2 \geq \frac{1}{4}.$$

Hence,

$$(\Delta x)^2 + (\Delta p)^2 \geq 1.$$

Then, for two-mode separable states

$$(\Delta(x_1 + x_2))^2 + (\Delta(p_1 - p_2))^2 \geq 2.$$

Any state violating this is entangled.

[Generalization: L.M. Duan, G. Giedke, J.I. Cirac, P. Zoller, Phys. Rev. Lett (2000); R. Simon, Phys. Rev. Lett (2000).]

1 Introduction

2 Entanglement witnesses

- Basic definitions
- Geometry of quantum states
- Linear entanglement witnesses
- Various constructions for entanglement witnesses
- Experiment with photons

3 Spin squeezing and entanglement

- Non-linear entanglement criteria
- Spin squeezing
- Generalized spin squeezing
- Experiments

Many-particle systems

- For spin- $\frac{1}{2}$ particles, we can measure the collective angular momentum operators:

$$J_l := \frac{1}{2} \sum_{k=1}^N \sigma_l^{(k)},$$

where $l = x, y, z$ and $\sigma_l^{(k)}$ a Pauli spin matrices.

- We can also measure the

$$(\Delta J_l)^2 := \langle J_l^2 \rangle - \langle J_l \rangle^2$$

variances.

Spin squeezing

Definition

Uncertainty relation for the spin coordinates

$$(\Delta J_x)^2 (\Delta J_y)^2 \geq \frac{1}{4} |\langle J_z \rangle|^2.$$

If $(\Delta J_x)^2$ is smaller than the standard quantum limit $\frac{1}{2} |\langle J_z \rangle|$ then the state is called **spin squeezed** (mean spin in the z direction!).

[M. Kitagawa and M. Ueda, Phys. Rev. A 47, 5138 (1993)]

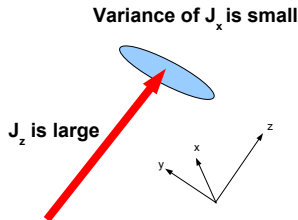

Spin squeezing II

Definition

Spin squeezing criterion for the detection of quantum entanglement

$$\frac{(\Delta J_x)^2}{\langle J_y \rangle^2 + \langle J_z \rangle^2} \geq \frac{1}{N}.$$

If a quantum state violates this criterion then it is entangled.

- Application: Quantum metrology, magnetometry. Used many times in experiments.

[A. Sørensen *et al.*, Nature **409**, 63 (2001);

experiments by E. Polzik, M.W. Mitchell with cold atomic ensembles;
M. Oberthaler, Ph. Treutlein with Bose-Einstein condensates.]

1 Introduction

2 Entanglement witnesses

- Basic definitions
- Geometry of quantum states
- Linear entanglement witnesses
- Various constructions for entanglement witnesses
- Experiment with photons

3 Spin squeezing and entanglement

- Non-linear entanglement criteria
- Spin squeezing
- Generalized spin squeezing
- Experiments

Complete set of the generalized spin squeezing criteria

- Let us assume that for a system we know only

$$\vec{J} := (\langle J_x \rangle, \langle J_y \rangle, \langle J_z \rangle),$$

$$\vec{K} := (\langle J_x^2 \rangle, \langle J_y^2 \rangle, \langle J_z^2 \rangle).$$

- Then any state violating the following inequalities is entangled

$$\langle J_x^2 \rangle + \langle J_y^2 \rangle + \langle J_z^2 \rangle \leq N(N+2)/4,$$

$$(\Delta J_x)^2 + (\Delta J_y)^2 + (\Delta J_z)^2 \geq N/2,$$

$$\langle J_k^2 \rangle + \langle J_l^2 \rangle - N/2 \leq (N-1)(\Delta J_m)^2,$$

$$(N-1) [(\Delta J_k)^2 + (\Delta J_l)^2] \geq \langle J_m^2 \rangle + N(N-2)/4,$$

where k, l, m takes all the possible permutations of x, y, z .
[GT, C. Knapp, O. Gühne, and H.J. Briegel, Phys. Rev. Lett. 2007]

The polytope

- The previous inequalities, for fixed $\langle J_{x/y/z} \rangle$, describe a polytope in the $\langle J_{x/y/z}^2 \rangle$ space.
- Separable states correspond to points inside the polytope. Note: Convexity comes up again!

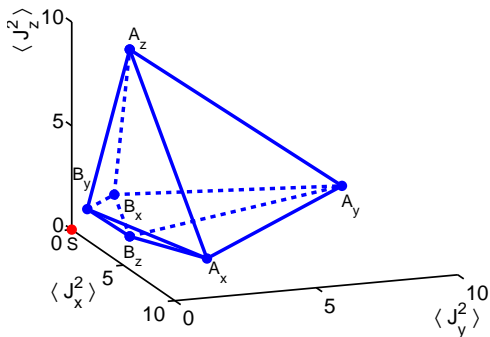

1 Introduction

2 Entanglement witnesses

- Basic definitions
- Geometry of quantum states
- Linear entanglement witnesses
- Various constructions for entanglement witnesses
- Experiment with photons

3 Spin squeezing and entanglement

- Non-linear entanglement criteria
- Spin squeezing
- Generalized spin squeezing
- Experiments

Dicke states I

- Separable states fulfill

$$\langle J_x^2 \rangle + \langle J_y^2 \rangle - \frac{N}{2} \leq (N-1)(\Delta J_z)^2.$$

- Symmetric Dicke state of the form

$$|D_N^{(\frac{N}{2})}\rangle = \binom{N}{\frac{N}{2}}^{-\frac{1}{2}} \sum_k \mathcal{P}_k(|0\rangle^{\otimes \frac{N}{2}} \otimes |1\rangle^{\otimes \frac{N}{2}}),$$

where the summation is over all the different permutations of $\frac{N}{2}$ 0's and $\frac{N}{2}$ 1's maximally violate the inequality.

- Multipartite entanglement can be detected in a similar way, measuring $\langle J_x^2 \rangle + \langle J_y^2 \rangle$ and $(\Delta J_z)^2$.

 Detecting Multiparticle Entanglement of Dicke States
Bernd Lücke,¹ Jan Peise,¹ Giuseppe Vitagliano,² Jan Arlt,³ Luis Santos,⁴ Géza Tóth,^{2,5,6} and Carsten Klempt¹¹*Institut für Quantenoptik, Leibniz Universität Hannover, Welfengarten 1, D-30167 Hannover, Germany*²*Department of Theoretical Physics, University of the Basque Country UPV/EHU, P.O. Box 644, E-48080 Bilbao, Spain*³*QUANTOP, Institut for Fysik og Astronomi, Aarhus Universitet, 8000 Århus C, Denmark*⁴*Institut für Theoretische Physik, Leibniz Universität Hannover, Appelstraße 2, D-30167 Hannover, Germany*⁵*IKERBASQUE, Basque Foundation for Science, E-48011 Bilbao, Spain*⁶*Wigner Research Centre for Physics, Hungarian Academy of Sciences, P.O. Box 49, H-1525 Budapest, Hungary*

(Received 27 February 2014; published 17 April 2014)

Recent experiments demonstrate the production of many thousands of neutral atoms entangled in their spin degrees of freedom. We present a criterion for estimating the amount of entanglement based on a measurement of the global spin. It outperforms previous criteria and applies to a wider class of entangled states, including Dicke states. Experimentally, we produce a Dicke-like state using spin dynamics in a Bose-Einstein condensate. Our criterion proves that it contains at least genuine 28-particle entanglement. We infer a generalized squeezing parameter of $-11.4(5)$ dB.

DOI: 10.1103/PhysRevLett.112.155304

PACS numbers: 67.85.-d, 03.67.Bg, 03.67.Mn, 03.75.Mn

Entanglement, one of the most intriguing features of quantum mechanics, is nowadays a key ingredient for many applications in quantum information science [1,2], quantum simulation [3,4], and quantum-enhanced metrology [5]. Entangled states with a large number of particles cannot be characterized via full state tomography [6], which is routinely used in the case of photons [7,8], trapped ions [9], or superconducting circuits [10,11]. A reconstruction of the full density matrix is hindered and finally prevented by the exponential increase of the required number of measurements. Furthermore, it is technically impossible to address all individual particles or even fundamentally forbidden if the particles occupy the same quantum state. Therefore, the entanglement of many-particle states is best characterized by measuring the expectation values and variances of the components of the collective spin $\mathbf{J} = (J_x, J_y, J_z)^T = \sum_i \mathbf{s}_i$, the sum of all individual spins \mathbf{s}_i in the ensemble.

In particular, the spin-squeezing parameter $\xi^2 = N(\Delta J_z)^2 / (\langle J_x \rangle^2 + \langle J_y \rangle^2)$ defines the class of spin-squeezed states for $\xi^2 < 1$. This inequality can be used to verify the presence of entanglement, since all spin-squeezed states are entangled [12]. Large clouds of entangled neutral atoms are typically prepared in such spin-squeezed states, as shown in thermal gas cells [13],

quantified by means of the so-called entanglement depth, defined as the number of particles in the largest nonseparable subset [see Fig. 1(a)]. There have been numerous experiments detecting multiparticle entanglement involving up to 14 qubits in systems, where the particles can be addressed individually [9,20–24]. Large ensembles of neutral atoms

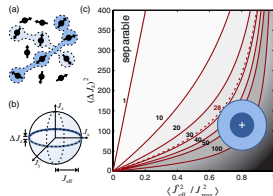

FIG. 1 (color online). Measurement of the entanglement depth for a total number of 8000 atoms. (a) The entanglement depth is given by the number of atoms in the largest nonseparable subset

Conclusions

- We discussed a method to construct entanglement witnesses:
 - Entanglement witnesses, i.e., conditions linear in operator expectation values,
 - Nonlinear entanglement witnesses, spin squeezing.
- For the transparencies, see

www.gtoth.eu

- See also

O. Gühne and G. Tóth,
Entanglement detection,
Phys. Rep. 474, 1 (2009); arxiv:0811.2803.

THANK YOU FOR YOUR ATTENTION!